

# HELISTAR

## EUDF-□□

雙法蘭式電磁離合器. 制動器組合

Double flange type clutch & brake unit

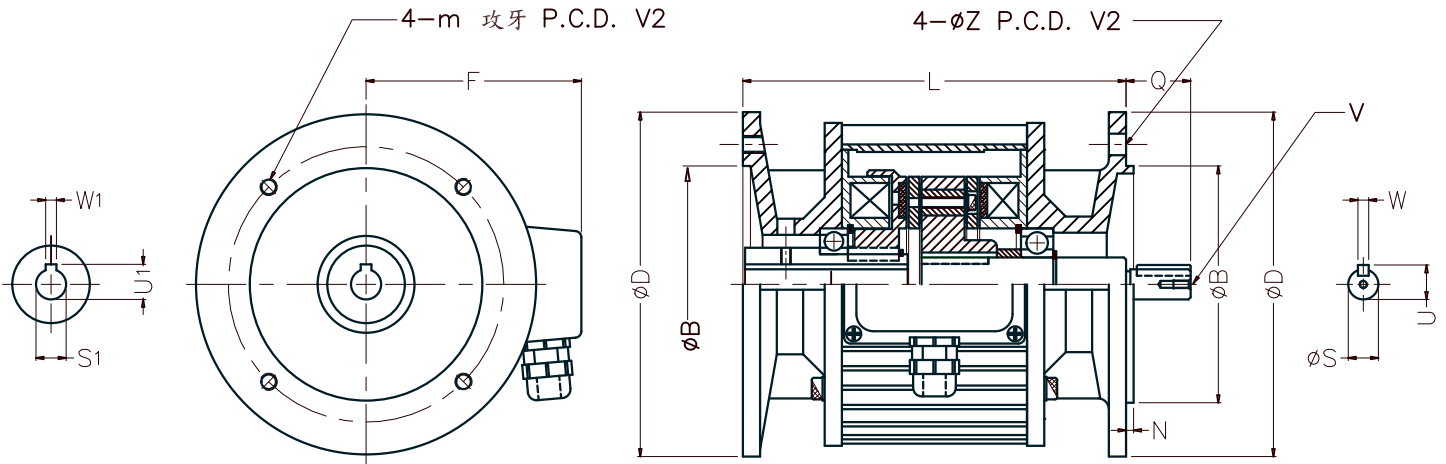

型號 Model		0.6	1.5		2.5		5	10	20	
本體 (Body)	B	95	95	110	110	130	130	180	230	
	D	140	140	160	160	200	200	250	300	
	F	70.5	84		101		117	145	177	
	L	129	158		178		210	276	320	
	m	M8	M8		M8	M10	M10	M12	M12	
	N	3	3	3.5	3.5		3.5	4	4	
	V	M4*0.7深8	M4*0.7深8		M6*1深11		M6*1深11	M6*1深11	M10*1.5深17	
	V2	115	115	130	130	165	165	215	265	
	Z	10	10		10	12	12	15	15	
軸部 (Shaft)	Q	23	23	30	30	40	40	50	60	80
	S	11	11	14	14	19	19	24	28	38
	S1	11	11	14	14	19	19	24	28	38
	U	12.5	12.5	16	16	21.5	21.5	27	31	41
	U1	12.5	12.5	16	16	21.5	21.5	27	31	41
	W	4	4	5	5	6	6	8	8	10
	W1	4	4	5	5	6	6	8	8	10
配合電機(4P)		1/4HP	1/4~1/2HP		1/2~1HP		1~2HP	3~5HP	7.5~10HP	